

Dimension of polynomial splines of mixed smoothness on T-meshes



Deepesh Toshniwal^{a,*}, Nelly Villamizar^b

^a Delft Institute of Applied Mathematics, Delft University of Technology, Netherlands

^b Department of Mathematics, Swansea University, United Kingdom of Great Britain and Northern Ireland

ARTICLE INFO

Article history:

Available online 13 May 2020

Keywords:

Splines
T-meshes
Mixed smoothness
Dimension formula
Homological algebra

ABSTRACT

In this paper we study the dimension of splines of mixed smoothness on axis-aligned T-meshes. This is the setting when different orders of smoothness are required across the edges of the mesh. Given a spline space whose dimension is independent of its T-mesh's geometric embedding, we present constructive and sufficient conditions that ensure that the smoothness across a subset of the mesh edges can be reduced while maintaining stability of the dimension. The conditions have a simple geometric interpretation. Examples are presented to show the applicability of the results on both hierarchical and non-hierarchical T-meshes. For hierarchical T-meshes it is shown that mixed smoothness spline spaces that contain the space of PHT-splines (Deng et al., 2008) always have stable dimension.

© 2020 The Author(s). Published by Elsevier B.V. This is an open access article under the CC BY license (<http://creativecommons.org/licenses/by/4.0/>).

1. Introduction

Polynomial splines on polyhedral partitions are ubiquitous in approximation theory, geometric modelling, and computational analysis. It is customary to ask splines to be C^r smooth across all mesh facets for a fixed choice of $r \in \mathbb{Z}_{\geq -1}$ that depends on the intended application. However, certain applications also require working with splines for which smoothness can be reduced across an arbitrary subset of the mesh facets; e.g., to model non-smooth or even discontinuous geometric features. Such splines will be said to have mixed smoothness, and they constitute the focus of this article.

Example (*Application to fluid flows around thin solids*). Consider the case of a thin solid immersed in an incompressible fluid flow, and a numerical simulation that employs a solid-conforming mesh, i.e., a mesh where the solid is modelled as the union of a subset of the facets. In general, we would like to use smooth splines for approximating the fluid pressure and velocity fields. However, unless the discrete pressure field is allowed to be discontinuous across the thin solid, the simulation results would be meaningless. At the same time, we would like to retain smoothness of the pressure field across the remaining facets. See Sauer and Luginisland (2018) for an example of such an application. ♦

An appealing feature of splines in applications is the flexibility in the choice of the underlying meshes. In particular, there is a rich history of the use of simplicial, quadrilateral and cuboidal meshes for uniform polynomial degrees and a fixed order of global smoothness, see e.g., Cirak et al. (2000) and Hughes et al. (2005). Univariate spline spaces and the

* Corresponding author.

E-mail addresses: d.toshniwal@tudelft.nl (D. Toshniwal), n.y.villamizar@swansea.ac.uk (N. Villamizar).

construction of a suitable spline basis for them, called the B-spline basis, are well understood, see de Boor (2001) for example. A spline basis for tensor product spline spaces can be easily defined on tensor product quadrilateral meshes by taking tensor products of univariate B-splines; this process can be directly extended to higher dimensions for building multivariate spline spaces. A comprehensive overview of splines on triangulations can be found in Lai and Schumaker (2007) and the references therein.

When applications require the resolution of the spline space to be increased on a subset of the mesh faces, the most common approach is to employ local subdivision. Spline constructions on such locally subdivided meshes have been proposed in Speleers et al. (2009); Schumaker and Wang (2012b) and Kang et al. (2014) for triangulations and in Sederberg et al. (2003); Giannelli et al. (2012) and Dokken et al. (2013) for quadrilateral meshes, among others. We will focus on the case of locally subdivided quadrilateral meshes, the so-called T-meshes. Examples of such meshes will be discussed in Section 5.

The study of multivariate splines, and bivariate splines on T-meshes in particular, poses an interesting challenge as the spline space dimension can depend on the geometric embedding of the mesh, see for instance Deng et al. (2006); Li et al. (2006); Li and Chen (2011); Schumaker and Wang (2012a) and Li and Wang (2019). In practice, identifying meshes where the dimension is stable – i.e., free from this dependence – is useful for avoiding cases where spline spaces on combinatorially and topologically equivalent meshes have different dimensions. Several techniques have been used for studying the dimension of multivariate splines. We will do so for splines of mixed smoothness using the homology-based approach introduced in Billera (1988), and therefore in the following we stick to a brief discussion of the same. It should be noted that other approaches such as Bernstein–Bézier methods (Alfeld and Schumaker, 1987) or smoothing cofactor-conformality (Li and Deng, 2016) are equally suited to study the problem, and may be alternatively used to achieve the same results that we do.

By interpreting splines as the top homology of a chain complex, Billera (1988) used tools from homological algebra for studying the dimension of splines. Modifications of the complexes proposed by Schenck and Stillman (1997a) and Schenck and Stillman (1997b) have since been used by Mourrain and Villamizar (2013) for bounding the spline space dimension on simplicial meshes in two and three dimensions. Schenck and Sorokina (2018) have recently studied the problem on simplicial meshes where one maximal face has been subdivided. On T-meshes, Mourrain (2014) provided bounds on the dimension of bi-degree (m, m') splines. Generalizations of the bounds from Mourrain and Villamizar (2013) and Mourrain (2014) to splines with local polynomial degree adaptivity been recently provided in Toshniwal and Hughes (2019) and Toshniwal et al. (2019). The tools from homology have also been applied to study of non-polynomial splines on T-meshes where, in particular, the ring structure of polynomials cannot be used; see Bracco et al. (2016a,b) and Bracco et al. (2019).

Let $\mathcal{R}_{mm'}^r$ denote the space of bi-degree (m, m') splines that are $r(\tau)$ smooth across mesh edge τ . As stated above, we will use homology-based techniques similar to the ones used in Billera (1988); Schenck and Stillman (1997b) and Mourrain (2014) to study the dimension of $\mathcal{R}_{mm'}^r$. Then, given that $\mathcal{R}_{mm'}^r$ has stable dimension, we provide sufficient conditions for preservation of this stability when the desired orders of smoothness are decreased across a subset of the mesh edges. Let us denote this latter spline space with $\mathcal{R}_{mm'}^s$, with $s(\tau) \leq r(\tau)$ for all edges τ . Note that in general the results proposed in Mourrain (2014) cannot be applied to compute the dimension of $\mathcal{R}_{mm'}^s$. This is because they require the smoothness across all horizontal (resp. vertical) edges that form a connected union to be the same; we do not impose the same restriction here. Instead of studying $\mathcal{R}_{mm'}^s$ from scratch, we use information from $\mathcal{R}_{mm'}^r$ to considerably simplify the problem. In particular, in Section 4 we provide sufficient conditions that ensure that the dimension of $\mathcal{R}_{mm'}^s$ can be computed combinatorially using local information only. The conditions are constructive in nature and have a simple geometric interpretation. Application of the results to both hierarchical and non-hierarchical T-meshes are presented in Section 5.

2. Preliminaries: splines, meshes and homology

This section will introduce the relevant notation that we will use for working with polynomial splines on T-meshes.

2.1. Splines on T-meshes

Definition 2.1 (T-mesh). A T-mesh \mathcal{T} of \mathbb{R}^2 is defined as:

- a finite collection \mathcal{T}_2 of axis-aligned rectangles σ that we consider as open sets of \mathbb{R}^2 having non-zero measure, called 2-cells or faces, together with
- a finite set \mathcal{T}_1 of closed axis-aligned segments τ , called 1-cells, which are edges of the (closure of the) faces $\sigma \in \mathcal{T}_2$, and
- the set \mathcal{T}_0 , of vertices γ , called 0-cells, of the edges $\tau \in \mathcal{T}_1$,

such that the following properties are satisfied:

- $\sigma \in \mathcal{T}_2 \Rightarrow$ the boundary $\partial\sigma$ of σ is a finite union of edges in \mathcal{T}_1 ,
- $\sigma, \sigma' \in \mathcal{T}_2 \Rightarrow \sigma \cap \sigma' = \partial\sigma \cap \partial\sigma'$ is a finite union of edges in $\mathcal{T}_1 \cup \mathcal{T}_0$, and,
- $\tau, \tau' \in \mathcal{T}_1$ with $\tau \neq \tau' \Rightarrow \tau \cap \tau' \in \mathcal{T}_0$.

The domain of the T-mesh is assumed to be connected and is defined as $\Omega := \cup_{\sigma \in \mathcal{T}_2} \sigma \subset \mathbb{R}^2$.

Sets of horizontal and vertical edges will be denoted by ${}^h\mathcal{T}_1$ and ${}^v\mathcal{T}_1$, respectively. Edges of the T-mesh are called interior edges if they intersect the interior of the domain of the T-mesh $\overset{\circ}{\Omega}$. Otherwise, they are called boundary edges. The set of interior edges will be denoted by $\overset{\circ}{\mathcal{T}}_1$; and the sets of interior horizontal and vertical edges will be denoted by ${}^h\overset{\circ}{\mathcal{T}}_1$ and ${}^v\overset{\circ}{\mathcal{T}}_1$, respectively. Similarly, if a vertex is in $\overset{\circ}{\Omega}$ it will be called an interior vertex, and a boundary vertex otherwise. The set of interior vertices will be denoted by $\overset{\circ}{\mathcal{T}}_0$. We will denote the number of i -cells with $t_i := \#\mathcal{T}_i$.

Assumption 2.2. The domain Ω is simply connected, and $\overset{\circ}{\Omega}$ is connected.

A T-mesh which satisfies Assumption 2.2 will be said to be simply connected. We define $\mathcal{P}_{mm'}$ as the vector space of polynomials of bi-degree at most (m, m') spanned by the monomials $s^i t^j$, $0 \leq i \leq m$ and $0 \leq j \leq m'$. If either of m or m' are negative, then $\mathcal{P}_{mm'} := 0$. The final ingredient that we need for defining a spline space on \mathcal{T} is a smoothness distribution on its edges.

Definition 2.3 (Smoothness distribution). The map $\mathbf{r} : \mathcal{T}_1 \rightarrow \mathbb{Z}_{\geq -1}$ is called a smoothness distribution if $\mathbf{r}(\tau) = -1$ for all $\tau \notin \overset{\circ}{\mathcal{T}}_1$.

Using this notation, we can define the spline space $\mathcal{R}_{mm'}^{\mathbf{r}}$ that forms the object of our study. From the following definition and the definition of \mathbf{r} , it will be clear that we are interested in obtaining highly local control over the smoothness of splines in $\mathcal{R}_{mm'}^{\mathbf{r}}$, a feature that is missing from the existing literature which studies spline on T-meshes.

Definition 2.4 (Spline space). Given mesh \mathcal{T} , bi-degree $(m, m') \in \mathbb{Z}_{\geq 0}^2$, smoothness distribution \mathbf{r} , we define the spline space $\mathcal{R}^{\mathbf{r}} \equiv \mathcal{R}_{mm'}^{\mathbf{r}}(\mathcal{T})$ as

$$\mathcal{R}_{mm'}^{\mathbf{r}}(\mathcal{T}) := \left\{ f : \forall \sigma \in \mathcal{T}_2 \ f|_{\sigma} \in \mathcal{P}_{mm'}, \text{ and } \forall \tau \in \overset{\circ}{\mathcal{T}}_1 \ f \in C^{\mathbf{r}(\tau)} \text{ smooth across } \tau \right\}. \tag{1}$$

From the above definition, the pieces of all splines in $\mathcal{R}^{\mathbf{r}}$ are constrained to meet with smoothness $\mathbf{r}(\tau)$ at an interior edge τ ; we will also define

$$\mathbf{r}_h(\gamma) := \min_{\substack{\tau \ni \gamma \\ \tau \in {}^v\mathcal{T}_1}} \mathbf{r}(\tau), \quad \mathbf{r}_v(\gamma) := \min_{\substack{\tau \ni \gamma \\ \tau \in {}^h\mathcal{T}_1}} \mathbf{r}(\tau).$$

We will use the following algebraic characterization of smoothness in this document. Proofs of this characterization can be found in several texts; e.g., see Chui (1988) and Billera (1988).

Lemma 2.5. For $\sigma, \sigma' \in \mathcal{T}_2$, let $\sigma \cap \sigma' = \tau \in \overset{\circ}{\mathcal{T}}_1$. A piecewise polynomial function equalling p and p' on σ and σ' , respectively, is at least r times continuously differentiable across τ if and only if

$$\ell_{\tau}^{r+1} \mid p - p',$$

where ℓ_{τ} is a non-zero linear polynomial vanishing on τ .

In line with the above characterization and for each interior edge τ , we define $\mathcal{J}_{\tau}^{\mathbf{r}}$ to be the vector subspace of $\mathcal{P}_{mm'}$ that contains all polynomial multiples of $\ell_{\tau}^{\mathbf{r}(\tau)+1}$; when $\mathbf{r}(\tau) = -1$, $\mathcal{J}_{\tau}^{\mathbf{r}}$ is simply defined to be $\mathcal{P}_{mm'}$. Similarly, for each interior vertex γ , we define $\mathcal{J}_{\gamma}^{\mathbf{r}} := \sum_{\tau \ni \gamma} \mathcal{J}_{\tau}^{\mathbf{r}}$.

Remark 2.6. In the above, we have suppressed the dependence of the different vector spaces on (m, m') to simplify the reading (and writing) of the text.

2.2. Topological chain complexes

Any spline $f \in \mathcal{R}^{\mathbf{r}}$ is a piecewise polynomial function on \mathcal{T} . We can explicitly refer to its piecewise polynomial nature by equivalently expressing it $\sum_{\sigma} [\sigma] f_{\sigma}$ with $f_{\sigma} := f|_{\sigma}$. This notation makes it clear that the polynomial f_{σ} is attached to the face σ of \mathcal{T} . Using this notation and Lemma 2.5, the spline space $\mathcal{R}^{\mathbf{r}}$ can be equivalently expressed as the kernel of the map $\bar{\partial}$,

$$\bar{\partial} : \bigoplus_{\sigma \in \mathcal{J}_2} [\sigma] \mathcal{P}_{mm'} \rightarrow \bigoplus_{\tau \in \mathcal{J}_1} [\tau] \mathcal{P}_{mm'} / \mathcal{J}_\tau^{\mathbf{r}},$$

defined by composing the boundary map ∂ with the natural quotient map.

As a result of this observation, the spline space $\mathcal{R}^{\mathbf{r}}$ can be interpreted as the top homology of a suitably defined chain complex $\mathcal{Q}^{\mathbf{r}}$,

$$\mathcal{Q}^{\mathbf{r}} : \quad \bigoplus_{\sigma \in \mathcal{J}_2} [\sigma] \mathcal{P}_{mm'} \longrightarrow \bigoplus_{\tau \in \mathcal{J}_1} [\tau] \mathcal{P}_{mm'} / \mathcal{J}_\tau^{\mathbf{r}} \longrightarrow \bigoplus_{\gamma \in \mathcal{J}_0} [\gamma] \mathcal{P}_{mm'} / \mathcal{J}_\gamma^{\mathbf{r}} \longrightarrow 0.$$

In other words, we have

$$\mathcal{R}^{\mathbf{r}} \cong \ker(\bar{\partial}) = H_2(\mathcal{Q}^{\mathbf{r}}).$$

As in Billera (1988); Schenck and Stillman (1997a) and Mourrain (2014), we will study \mathcal{Q} using the following short exact sequence of chain complexes,

$$\begin{array}{ccccccc} & & 0 & & 0 & & \\ & & \downarrow & & \downarrow & & \\ \mathcal{J}^{\mathbf{r}} : & 0 & \longrightarrow & \bigoplus_{\tau \in \mathcal{J}_1} [\tau] \mathcal{J}_\tau^{\mathbf{r}} & \longrightarrow & \bigoplus_{\gamma \in \mathcal{J}_0} [\gamma] \mathcal{J}_\gamma^{\mathbf{r}} & \longrightarrow 0 \\ & \downarrow & & \downarrow & & \downarrow & \\ \mathcal{C} : & \bigoplus_{\sigma \in \mathcal{J}_2} [\sigma] \mathcal{P}_{mm'} & \longrightarrow & \bigoplus_{\tau \in \mathcal{J}_1} [\tau] \mathcal{P}_{mm'} & \longrightarrow & \bigoplus_{\gamma \in \mathcal{J}_0} [\gamma] \mathcal{P}_{mm'} & \longrightarrow 0 \\ & \downarrow & & \downarrow & & \downarrow & \\ \mathcal{Q}^{\mathbf{r}} : & \bigoplus_{\sigma \in \mathcal{J}_2} [\sigma] \mathcal{P}_{mm'} & \longrightarrow & \bigoplus_{\tau \in \mathcal{J}_1} [\tau] \mathcal{P}_{mm'} / \mathcal{J}_\tau^{\mathbf{r}} & \longrightarrow & \bigoplus_{\gamma \in \mathcal{J}_0} [\gamma] \mathcal{P}_{mm'} / \mathcal{J}_\gamma^{\mathbf{r}} & \longrightarrow 0 \\ & & & \downarrow & & \downarrow & \\ & & & 0 & & 0 & \end{array} \tag{2}$$

The following result and its proof can be found in, for instance, Mourrain (2014). We include it here for completeness.

Theorem 2.7. For a simply connected T -mesh \mathcal{J}_2 , the dimension of the spline space of bi-degree (m, m') and smoothness distribution \mathbf{r} is given by

$$\dim(\mathcal{R}^{\mathbf{r}}) = \chi(\mathcal{Q}^{\mathbf{r}}) + \dim(H_0(\mathcal{J}^{\mathbf{r}})),$$

where $H_0(\mathcal{J}^{\mathbf{r}})$ is the zeroth homology of the complex $\mathcal{J}^{\mathbf{r}}$ and $\chi(\mathcal{Q}^{\mathbf{r}})$ is the Euler characteristic of the complex $\mathcal{Q}^{\mathbf{r}}$,

$$\begin{aligned} \chi(\mathcal{Q}^{\mathbf{r}}) &= t_2(m+1)(m'+1) \\ &\quad - (m+1) \sum_{\tau \in h\mathcal{J}_1} (\min(\mathbf{r}(\tau), m') + 1) - (m'+1) \sum_{\tau \in v\mathcal{J}_1} (\min(\mathbf{r}(\tau), m) + 1) \\ &\quad + \sum_{\gamma \in \mathcal{J}_0} (\min(\mathbf{r}_h(\gamma), m) + 1)(\min(\mathbf{r}_v(\gamma), m') + 1). \end{aligned}$$

Proof. Following Assumption 2.2, it is clear that $H_0(\mathcal{C}) = 0 = H_1(\mathcal{C})$. Moreover, from the long exact sequence of homology implied by the short exact sequence of complexes in Equation (2), we obtain

$$H_0(\mathcal{Q}^{\mathbf{r}}) = 0, \quad H_0(\mathcal{J}^{\mathbf{r}}) \cong H_1(\mathcal{Q}^{\mathbf{r}}).$$

Therefore, the claim follows upon recalling $\mathcal{R}^{\mathbf{r}} \cong H_2(\mathcal{Q}^{\mathbf{r}})$ and the definition of the Euler characteristic of $\mathcal{Q}^{\mathbf{r}}$,

$$\begin{aligned} \chi(\mathcal{Q}^{\mathbf{r}}) &= \dim(\mathcal{Q}_2^{\mathbf{r}}) - \dim(\mathcal{Q}_1^{\mathbf{r}}) + \dim(\mathcal{Q}_0^{\mathbf{r}}), \\ &= \dim(H_2(\mathcal{Q}^{\mathbf{r}})) - \dim(H_1(\mathcal{Q}^{\mathbf{r}})) + \dim(H_0(\mathcal{Q}^{\mathbf{r}})). \quad \square \end{aligned}$$

Corollary 2.8. If $\dim(H_0(\mathcal{J}^{\mathbf{r}})) = 0$, then the dimension is stable and can be computed using the following (combinatorial) formula,

$$\dim(\mathcal{R}^{\mathbf{r}}) = \chi(\mathcal{Q}^{\mathbf{r}}).$$

3. Spline space $\mathcal{R}^s \supseteq \mathcal{R}^r$ of reduced regularity

In this intermediate section, we will relate the dimension of the spline space \mathcal{R}^r to the dimension of a spline space \mathcal{R}^s obtained by relaxing the regularity requirements. That is, for all interior edges τ , it will be assumed that $\mathbf{s}(\tau) \leq \mathbf{r}(\tau)$. This relationship will be utilized in the next section to present sufficient conditions for the dimension of \mathcal{R}^s to be stable.

For the spline space \mathcal{R}^s , let the first and last chain complexes in Equation (2) be denoted by \mathcal{J}^s and \mathcal{Q}^s , respectively. The spline space dimension is therefore given as below,

$$\dim(\mathcal{R}^s) = \dim(H_2(\mathcal{Q}^s)) = \chi(\mathcal{Q}^s) + \dim(H_0(\mathcal{J}^s)). \tag{3}$$

Then, by definition of the smoothness distributions \mathbf{r} and \mathbf{s} , we have the following inclusion map from \mathcal{J}^r to \mathcal{J}^s ,

$$\mathcal{J}^r \xrightarrow{\iota} \mathcal{J}^s.$$

Proposition 3.1. *If $H_0(\mathcal{J}^r) = 0$, then $H_0(\mathcal{J}^s) \cong H_0(\mathcal{J}^s/\mathcal{J}^r)$.*

Proof. The claim follows from the following short exact sequence of chain complexes (and the long exact sequence of homology implied by it),

$$0 \longrightarrow \mathcal{J}^r \longrightarrow \mathcal{J}^s \longrightarrow \mathcal{J}^s/\mathcal{J}^r \longrightarrow 0. \quad \square$$

The previous result considerably simplifies the task of identifying when $H_0(\mathcal{J}^s)$ will vanish because $H_0(\mathcal{J}^s/\mathcal{J}^r)$ can be a simpler object to study. Let \mathcal{T}_1^s be the set of edges τ for which $\mathbf{s}(\tau) < \mathbf{r}(\tau)$, and let \mathcal{T}_0^s be the set of interior vertices of the edges $\tau \in \mathcal{T}_1^s$. The following result follows.

Lemma 3.2. *The complex $\mathcal{J}^s/\mathcal{J}^r$ is supported only on \mathcal{T}_1^s and \mathcal{T}_0^s .*

Proof. The claim follows from the definition of the complexes \mathcal{J}^s and \mathcal{J}^r . Indeed, if $\mathbf{s}(\tau) = \mathbf{r}(\tau)$, then $\mathcal{J}_\tau^s = \mathcal{J}_\tau^r$ and the cokernel of ι is zero on τ ; similarly for the vertices. \square

4. Dimension of splines of mixed smoothness

This section contains our main results. Starting from a spline space with stable dimension, we specify sufficient conditions when the dimension can still be computed using Corollary 2.8 after the smoothness requirements are relaxed for a subset of the interior edges. We first define the weight of a connected union of horizontal or vertical edges.

Definition 4.1 (Segment and its weight). Let $\rho \subseteq \overset{\circ}{\mathcal{T}}_1 \cup \mathcal{T}_0$ be a finite set of horizontal (resp., vertical) edges $\tau \in \overset{\circ}{\mathcal{T}}_1$ together with their vertices $\gamma \in \tau$, such that $\bigcup_{\tau \in \rho} \tau$ is connected and it contains at least one edge. Then ρ will be called a horizontal (resp., vertical) segment. Its weight $\omega^r(\rho)$ will be defined as

$$\omega^r(\rho) := \begin{cases} \sum_{\gamma \in \rho} (m - \mathbf{r}_h(\gamma))_+ & \text{if } \rho \text{ is horizontal,} \\ \sum_{\gamma \in \rho} (m' - \mathbf{r}_v(\gamma))_+ & \text{if } \rho \text{ is vertical.} \end{cases}$$

Theorem 4.2. *Let \mathbf{r} be such that $H_0(\mathcal{J}^r) = 0$ and let ρ be a segment of the mesh. Consider the space \mathcal{R}^s where the smoothness distribution \mathbf{s} is defined as follows for some $r \in \mathbb{Z}_{\geq -1}$,*

$$\mathbf{s}(\tau) = \begin{cases} \mathbf{r}(\tau) & \text{for } \tau \notin \rho \cap \overset{\circ}{\mathcal{T}}_1, \\ r \leq \mathbf{r}(\tau) & \text{for } \tau \in \rho \cap \overset{\circ}{\mathcal{T}}_1. \end{cases}$$

If either one of the following two requirements is satisfied,

- (a) ρ is horizontal and $\omega^s(\rho) \geq m + 1$; otherwise, $\omega^s(\rho) \geq m' + 1$;
- (b) $\rho \subsetneq \rho'$ for some segment ρ' , and $\mathbf{s}(\tau) \leq r$ for all $\tau \in \rho'$

then $H_0(\mathcal{J}^s) = 0$ and $\dim(\mathcal{R}^s) = \chi(\mathcal{Q}^s)$.

Proof. By Lemma 3.2, the study of $H_0(\mathcal{J}^s)$ reduces to the study of $H_0(\mathcal{J}^s/\mathcal{J}^r)$ on the segment ρ – an essentially one dimensional problem. We will provide the proof for when ρ is a horizontal segment as shown below; the proof for vertical segments is analogous. As shown, ρ contains the edges $\tau_1, \dots, \tau_k \in \overset{\circ}{\mathcal{J}}_1$ and the vertices $\gamma_0, \gamma_1, \dots, \gamma_k$. By definition ρ contains at least two different vertices.

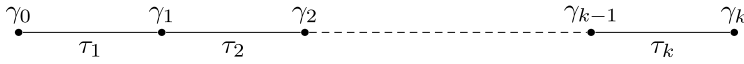

Condition (a). Let us first prove the claim for the setting when ρ satisfies condition (a) above. Let ℓ_ρ be a non-zero linear polynomial that vanishes on ρ , and let ℓ_0, \dots, ℓ_k be non-zero linear polynomials that vanish on vertical edges that contain the vertices $\gamma_0, \dots, \gamma_k$, respectively. Let r_0, \dots, r_k be such that $r_i = \mathbf{r}_h(\gamma_i) = \mathbf{s}_h(\gamma_i)$.

By definition, $\mathcal{J}_\tau^s = \{\ell_\rho^{r+1} f : f \in \mathcal{P}_{m(m'-r-1)}\}$. Since $\omega^s(\rho) \geq m + 1$ and the vertices γ_i are all different then, for any $i \neq j$, there are polynomials $f_i, i = 0, \dots, k$, such that $1 = \sum_{i=0}^k \ell_i^{r_i+1} f_i$ (Mourrain, 2014, Proposition 1.8). Thus we can write

$$\mathcal{J}_\tau^s = \ell_\rho^{r+1} \sum_{i=0}^k \ell_i^{r_i+1} \mathcal{P}_{(m-r_i-1)(m'-r-1)}.$$

Then, any element $\ell_\rho^{r+1} f$ in $\mathcal{J}_{\gamma_i}^s$ can be written as the sum of polynomials $\ell_\rho^{r+1} \ell_i^{r_i+1} f_i \in \mathcal{J}_{\gamma_i}^s$ for some f_i of degree $\leq m - r_i - 1, i = 0, \dots, k$. But $H_0(\mathcal{J}^r) = 0$ by hypothesis and $\ell_\rho^{r+1} \ell_i^{r_i+1} f_i \in \mathcal{J}_{\gamma_i}^r$ for all i . Hence, in the complex $\mathcal{J}^s/\mathcal{J}^r$ all $[\gamma_i] \mathcal{J}_{\gamma_i}^s/\mathcal{J}_{\gamma_i}^r$ are in the image of the boundary map. Therefore, $H_0(\mathcal{J}^s/\mathcal{J}^r) = 0$ and the claim follows from Proposition 3.1.

Condition (b). Let us now look at the case when ρ satisfies condition (b). Without loss of generality, let $\rho' \supseteq \rho$ be a segment such that γ_0 lies in the interior of $\bigcup_{\tau \in \rho'} \tau$. Then, since $\mathbf{s}(\tau) \leq r$ for all $\tau \in \rho'$, and since \mathbf{s} and \mathbf{r} differ only on the edge $\tau \in \rho$,

the vertex γ_0 is zeroed out in the quotient $\mathcal{J}^s/\mathcal{J}^r$. Then, for any $1 \leq i \leq k$, any element $\ell_\rho^{r+1} f \in \mathcal{J}_{\gamma_i}^s$ can be expressed in the image of the boundary map as

$$[\gamma_i] \ell_\rho^{r+1} f = \partial \left(\sum_{j=1}^i [\tau_j] \ell_\rho^{r+1} f \right),$$

where $\ell_\rho^{r+1} f \in \mathcal{J}_{\tau_j}^s$ for all $1 \leq j \leq k$. This implies that $H_0(\mathcal{J}^s/\mathcal{J}^r) = 0$ and the claim once again follows from Proposition 3.1. \square

Remark 4.3. Theorem 4.2 discusses the dimension when the smoothness is reduced across a single segment of the mesh. Its successive applications can help us compute the dimension of a large class of splines on \mathcal{T} with mixed smoothness.

Let us present an example application of Theorem 4.2 to a special space of splines called PHT-splines (Deng et al., 2008). Corollary 4.6 helps compute the dimension of PHT-splines of mixed smoothness; alternatively, Bernstein–Bézier techniques can be used to obtain the result.

Definition 4.4 ($(m + 1, m' + 1)$ smoothness distribution). The smoothness distribution \mathbf{r} will be called an $(m + 1, m' + 1)$ smoothness distribution if for all edges $\tau \in {}^h\mathcal{J}_1$ (resp., ${}^v\mathcal{J}_1$), $\mathbf{r}(\tau) \leq (m' - 1)/2$ (resp., $(m - 1)/2$).

Theorem 4.5. Let \mathbf{r} be an $(m + 1, m' + 1)$ smoothness distribution, and let \mathbf{s} be any smoothness distribution such that $\mathbf{s}(\tau) \leq \mathbf{r}(\tau)$ for all edges of \mathcal{T} . If $H_0(\mathcal{J}^r) = 0$, then $H_0(\mathcal{J}^s) = 0$ and $\dim(\mathcal{R}^s) = \chi(\mathcal{Q}^s)$.

Proof. Since each interior edge is intersected by two transversal edges on its boundary, by the definition of \mathbf{r} the weight of each interior edge satisfies condition (b) from Theorem 4.2. Therefore, we can move from the smoothness distribution \mathbf{r} to \mathbf{s} one edge at a time; at each stage, $H_0(\mathcal{J}) = 0$ and Theorem 4.2(b) will be applicable. \square

Corollary 4.6 (PHT-splines of mixed smoothness). Let \mathcal{T} be a hierarchical T-mesh and let \mathbf{r} be an $(m + 1, m' + 1)$ smoothness distribution such that $\mathbf{r}(\tau) = \mathbf{r}(\tau')$ for all edges τ and τ' that belong to the same segment. Then, for any other smoothness distribution \mathbf{s} as in Theorem 4.5, we have

$$\dim(\mathcal{R}^s) = \chi(\mathcal{Q}^s).$$

Proof. From Mourrain (2014), $H_0(\mathcal{J}^r) = 0$. Therefore, the claim follows from Theorem 4.5. \square

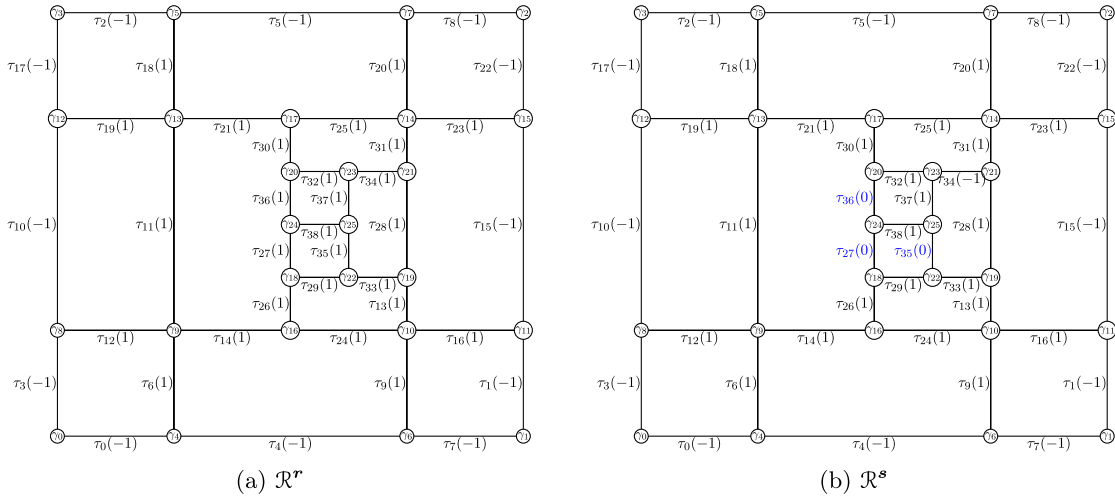

Fig. 1. The above figures correspond to the PHT-spline setting considered in Example 5.1. The smoothness required across each edge has been annotated in parentheses next to the edge label. Figure (a) shows the initial smoothness distribution, while Figure (b) shows the modified initial distributions; the modifications are limited to the edges labelled in blue. (For interpretation of the colours in the figure(s), the reader is referred to the web version of this article.)

5. Examples

This section presents examples of settings where Theorem 4.2 applies, and also where it does not. In particular, we show that $H_0(\mathcal{J}^s)$ can be non-trivial when the conditions of Theorem 4.2 are not met.

Example 5.1 (PHT-splines of mixed smoothness). Consider the PHT-spline space \mathcal{R}_{33}^r shown in Fig. 1(a). From Corollary 4.6, we can reduce the smoothness across any arbitrary edge and the dimension will still be given by the Euler characteristic of \mathcal{Q}^r . One such modification is shown in Fig. 1(b) where the smoothness across edges τ_{27} , τ_{34} , τ_{35} and τ_{36} have been reduced. The dimensions of the spaces can be easily computed to be the following,

$$\dim(\mathcal{R}^r) = 64, \quad \dim(\mathcal{R}^s) = 66. \quad \blacklozenge$$

Example 5.2 (Splines of mixed smoothness; hierarchical T-mesh). Consider the space of bi-cubic splines \mathcal{R}_{33}^r for the smoothness distribution shown in Fig. 2(a). In Figures (b)–(e), we successively reduce the smoothness across the edges labelled in blue while ensuring that the conditions of Theorem 4.2 are met. As a result, at each step of smoothness reduction, we have $H_0(\mathcal{J}^{s_i}) = 0, i = 0, \dots, 3$. The dimensions of the corresponding spline spaces can then be easily computed using the Euler characteristics of complexes \mathcal{Q}^{s_i} ,

$$\begin{aligned} \dim(\mathcal{R}^r) &= 56, \quad \dim(\mathcal{R}^{s_0}) = 57, \quad \dim(\mathcal{R}^{s_1}) = 58, \\ \dim(\mathcal{R}^{s_2}) &= 58, \quad \dim(\mathcal{R}^{s_3}) = 59. \end{aligned}$$

On the other hand, reducing the smoothness from Figure (a) to Figure (f) does not satisfy the conditions of Theorem 4.2. Indeed, for $\rho = \{\tau_{30}, \tau_{37}, \gamma_{17}, \gamma_{20}, \gamma_{25}\}$, it can be verified that $\omega^{s_4}(\rho) = 3 < m' + 1 = 4$. In this case, it can also be computed (using Macaulay2 (Grayson and Stillman), for instance) that $\dim(H_0(\mathcal{J}^{s_4})) = 1. \quad \blacklozenge$

Example 5.3 (Splines of mixed smoothness; non-hierarchical T-mesh). Consider the space of bi-cubic splines \mathcal{R}_{33}^r for the smoothness distribution shown in Fig. 3(a). Note that in this case the T-mesh cannot be constructed hierarchically. Nevertheless, it is possible to use results from Li and Wang (2019) to verify that $H_0(\mathcal{J}^r) = 0$ and $\dim(\mathcal{R}^r) = \chi(\mathcal{Q}^r) = 64$. Then, using Theorem 4.5, we see that we can reduce the smoothness across any subset of edges and maintain $H_0(\mathcal{J}^s) = 0$ for the new smoothness distribution \mathbf{s} . One such case has been shown in Fig. 3(b), and the corresponding dimension of the space is given by $\dim(\mathcal{R}^s) = \chi(\mathcal{Q}^s) = 71. \quad \blacklozenge$

Remark 5.4. As illustrated in the above examples, our results can be combined with others, e.g., Mourrain (2014) and Li and Wang (2019), to compute the dimensions of a very general class of spline spaces. While it is always possible to directly use the other methods for this task, one can easily find simple cases where our approach gives superior results.

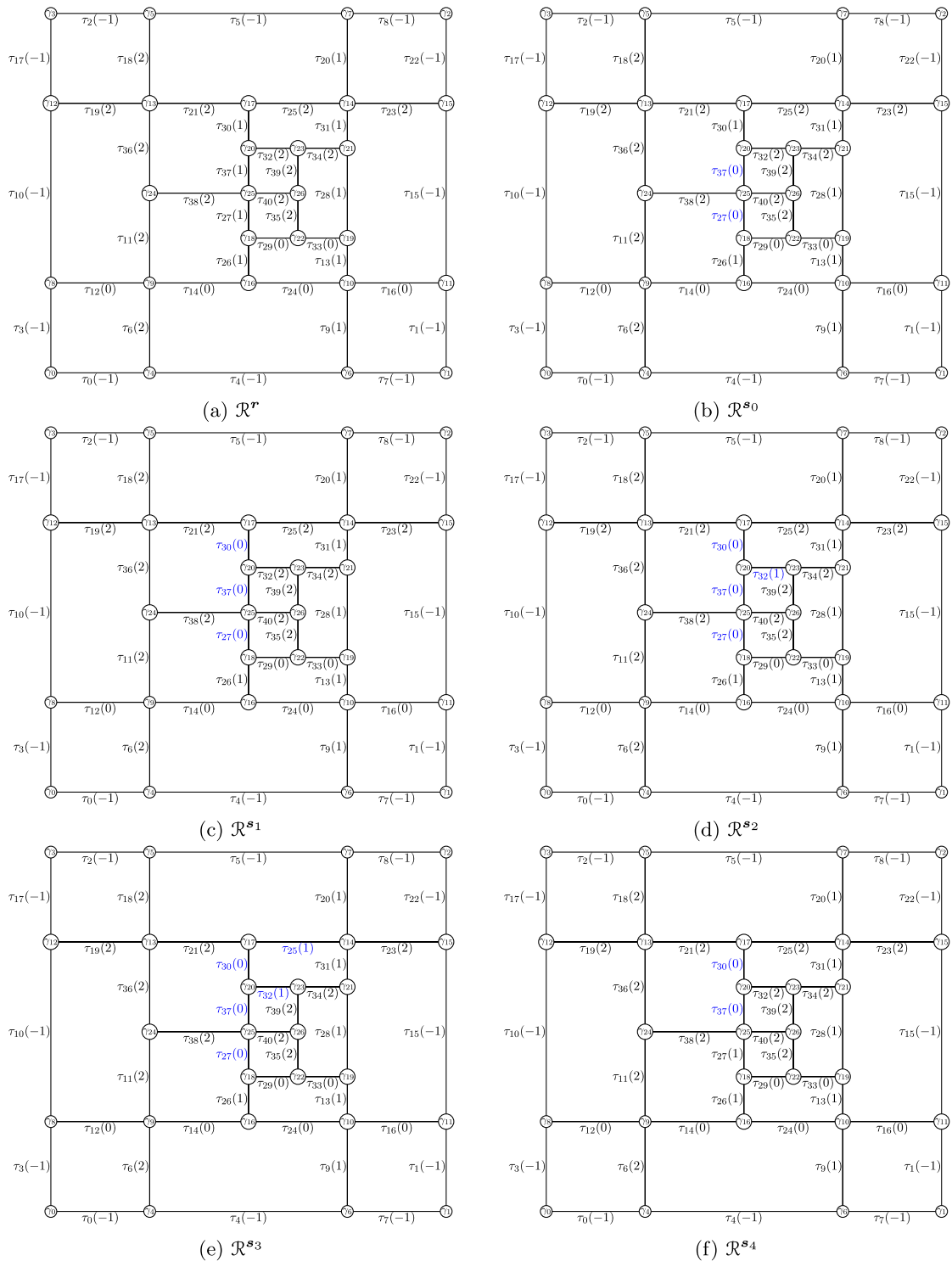

Fig. 2. The above figures correspond to the bi-cubic spline space considered in Example 5.2. The smoothness required across each edge has been annotated in parentheses next to the edge label. The smoothness distributions in Figures (b)–(f) differ from the one in Figure (a) only on the edges labelled in blue.

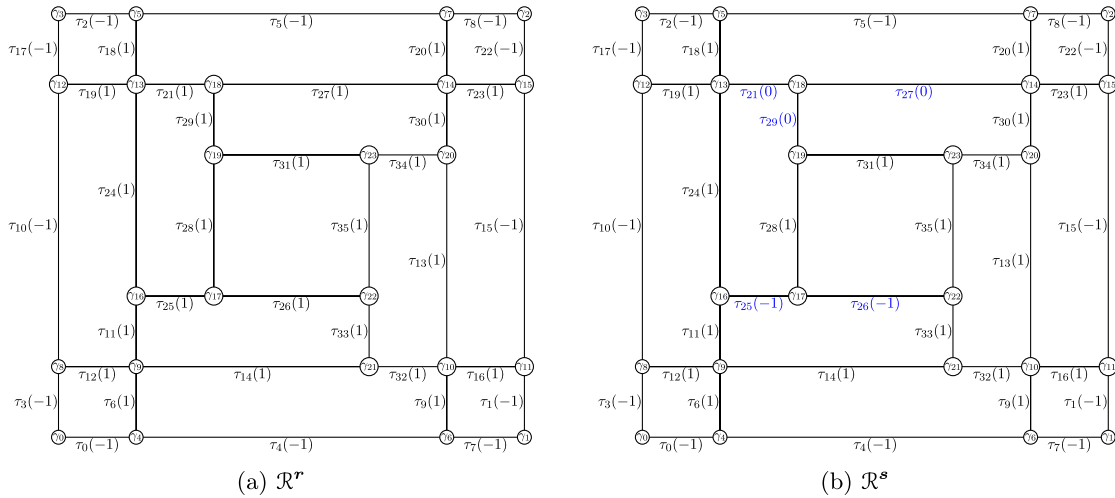
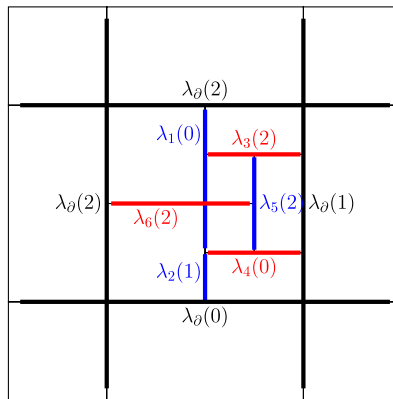

Fig. 3. The above figures correspond to the setting considered in Example 5.3. The smoothness required across each edge has been annotated in parentheses next to the edge label. Figure (a) shows the initial smoothness distribution, while Figure (b) shows the modified initial distributions; the modifications are limited to the edges labelled in blue.

For instance, as commented earlier, the approach of Mourrain (2014) works best when the smoothness across all connected horizontal (resp. vertical) edges is the same. Using the same terminology as in Mourrain (2014), define *maximal segments* as maximal connected unions of parallel edges with the same smoothness. Let us denote these maximal segments with the symbol λ . Then, as shown in Mourrain (2014), the homology term $H_0(\mathcal{J})$ can be described solely in terms of maximal segments. In fact, only maximal segments that do not intersect the mesh boundary may contribute to the dimension of $H_0(\mathcal{J})$. Let us apply this approach to the spline space corresponding to Fig. 2(c) – the corresponding interior horizontal, interior vertical and boundary maximal segments have been displayed as thick red, blue and black lines, respectively, in the figure on the right. The smoothness across each maximal segment has been annotated in parentheses next to its label.



Then, only the red and blue maximal segments λ_i , $1 \leq i \leq 6$, will contribute to $H_0(\mathcal{J})$; all black maximal segments labelled as λ_θ will not contribute as they intersect the boundary (Mourrain, 2014). Therefore, upon ordering the λ_i in the following manner,

$$\lambda_5 > \lambda_6 > \lambda_3 > \lambda_2 > \lambda_4 > \lambda_1,$$

and following the proof of (Mourrain, 2014, Theorem 3.7), the bounds on the dimension of the spline space simplify to

$$0 \leq \dim H_0(\mathcal{J}) \leq (m' + 1 - \omega(\lambda_1))(m' - r(\lambda_1)) = (3 + 1 - 1)(3 - 0) = 9.$$

In contrast, as shown in Example 5.2, our approach allowed us to show that $\dim H_0(\mathcal{J}) = 0$.

6. Conclusions

Smooth polynomial splines are immensely versatile and are routinely utilized for challenging applications in, for instance, geometric modelling and computational analysis. However, certain tasks also require working with splines of reduced

smoothness, at least locally; e.g., geometric objects containing C^0 feature lines, solutions to physical problems that show localized discontinuities. Local control over the smoothness can be very beneficial in such cases and can lead to great improvements in the quality of the output. In this paper we have studied the dimension of bi-degree splines on T-meshes when different orders of smoothness are required across different mesh edges. Reducing the problem to an essentially univariate problem, we have provided sufficient conditions that ensure that the dimension can be combinatorially computed using only local information. The conditions are constructive in nature and have simple geometric interpretation. A forthcoming paper will focus on the construction of a normalized B-spline-like basis for such spline spaces.

Declaration of competing interest

The authors declare that they have no known competing financial interests or personal relationships that could have appeared to influence the work reported in this paper.

References

- Alfeld, P., Schumaker, L.L., 1987. The dimension of bivariate spline spaces of smoothness r for degree $d \geq 4r + 1$. *Constr. Approx.* 3 (1), 189–197.
- Billera, L.J., 1988. Homology of smooth splines: generic triangulations and a conjecture of Strang. *Trans. Am. Math. Soc.* 310 (1), 325–340.
- de Boor, C., 2001. *A Practical Guide to Splines*, revised edition. Springer-Verlag.
- Bracco, C., Lyche, T., Manni, C., Roman, F., Speleers, H., 2016a. Generalized spline spaces over T-meshes: dimension formula and locally refined generalized B-splines. *Appl. Math. Comput.* 272, 187–198.
- Bracco, C., Lyche, T., Manni, C., Roman, F., Speleers, H., 2016b. On the dimension of Tchebycheffian spline spaces over planar T-meshes. *Comput. Aided Geom. Des.* 45, 151–173.
- Bracco, C., Lyche, T., Manni, C., Speleers, H., 2019. Tchebycheffian spline spaces over planar T-meshes: dimension bounds and dimension instabilities. *J. Comput. Appl. Math.* 349, 265–278.
- Chui, C.K., 1988. *Multivariate Splines*, vol. 54. Siam.
- Cirak, F., Ortiz, M., Schröder, P., 2000. Subdivision surfaces: a new paradigm for thin-shell finite-element analysis. *Int. J. Numer. Methods Eng.* 47, 2039–2072.
- Deng, J., Chen, F., Feng, Y., 2006. Dimensions of spline spaces over T-meshes. *J. Comput. Appl. Math.* 194 (2), 267–283.
- Deng, J., Chen, F., Li, X., Hu, C., Tong, W., Yang, Z., Feng, Y., 2008. Polynomial splines over hierarchical T-meshes. *Graph. Models* 70, 76–86.
- Dokken, T., Lyche, T., Pettersen, K.F., 2013. Polynomial splines over locally refined box-partitions. *Comput. Aided Geom. Des.* 30, 331–356.
- Giannelli, C., Jüttler, B., Speleers, H., 2012. THB-splines: The truncated basis for hierarchical splines. *Comput. Aided Geom. Des.* 29, 485–498.
- Grayson, D.R., Stillman, M.E. Macaulay2, a software system for research in algebraic geometry. Available at <https://faculty.math.illinois.edu/Macaulay2/>.
- Hughes, T.J.R., Cottrell, J.A., Bazilevs, Y., 2005. Isogeometric analysis: CAD, finite elements, NURBS, exact geometry and mesh refinement. *Comput. Methods Appl. Mech. Eng.* 194, 4135–4195.
- Kang, H., Chen, F., Deng, J., 2014. Hierarchical B-splines on regular triangular partitions. In: *Geometric Modeling and Processing 2014*. *Graph. Models* 76 (5), 289–300.
- Lai, M.-J., Schumaker, L.L., 2007. *Spline Functions on Triangulations*, vol. 110. Cambridge University Press.
- Li, X., Chen, F., 2011. On the instability in the dimension of spline spaces over T-meshes. *Comput. Aided Geom. Des.* 28 (7), 420–426.
- Li, X., Deng, J., 2016. On the dimension of spline spaces over T-meshes with smoothing cofactor-conformality method. *Comput. Aided Geom. Des.* 41, 76–86.
- Li, C., Wang, P., 2019. The instability in the dimensions of spline spaces over T-meshes with nested T-cycles. *Numer. Math., Theory Methods Appl.* 12 (1), 187–211.
- Li, C.-J., Wang, R.-H., Zhang, F., 2006. Improvement on the dimensions of spline spaces on t-mesh. *J. Inf. Comput. Sci.* 3, 235.
- Mourrain, B., 2014. On the dimension of spline spaces on planar T-meshes. *Math. Comput.* 83 (286), 847–871.
- Mourrain, B., Villamizar, N., 2013. Homological techniques for the analysis of the dimension of triangular spline spaces. *J. Symb. Comput.* 50, 564–577.
- Sauer, R.A., Luginsland, T., 2018. A monolithic fluid–structure interaction formulation for solid and liquid membranes including free-surface contact. *Comput. Methods Appl. Mech. Eng.* 341, 1–31.
- Schenck, H., Sorokina, T., 2018. Subdivision and spline spaces. *Constr. Approx.* 47 (2), 237–247.
- Schenck, H., Stillman, M., 1997a. A family of ideals of minimal regularity and the Hilbert series of $C^r(\Delta)$. *Adv. Appl. Math.* 19 (2), 169–182.
- Schenck, H., Stillman, M., 1997b. Local cohomology of bivariate splines. *J. Pure Appl. Algebra* 117, 535–548.
- Schumaker, L.L., Wang, L., 2012a. Approximation power of polynomial splines on t-meshes. *Comput. Aided Geom. Des.* 29 (8), 599–612.
- Schumaker, L.L., Wang, L., 2012b. Splines on triangulations with hanging vertices. *Constr. Approx.* 36 (3), 487–511.
- Sederberg, T.W., Zheng, J., Bakenov, A., Nasri, A., 2003. T-splines and T-NURCCs. *ACM Transactions on Graphics (TOG)*, vol. 22. ACM, pp. 477–484.
- Speleers, H., Dierckx, P., Vandewalle, S., 2009. Quasi-hierarchical Powell–Sabin B-splines. *Comput. Aided Geom. Des.* 26 (2), 174–191.
- Toshniwal, D., Hughes, T.J.R., 2019. Polynomial splines of non-uniform degree on triangulations: combinatorial bounds on the dimension. *Comput. Aided Geom. Des.* 75, 101763.
- Toshniwal, D., Mourrain, B., Hughes, T.J.R., 2019. Polynomial spline spaces of non-uniform bi-degree on T-meshes: combinatorial bounds on the dimension. arXiv:1903.05949 [math].